

## Information for Lot 9 of ErP (Ecodesign)

This addendum addresses European Union (EU) Ecodesign requirements for servers and storage products. All data and ratings within this addendum are in reference only to the Supermicro product(s) in the manual. The below information conforms to requirements laid down in Annex II of the Commission Regulation 2019/424.

- 3(1)(a): See Section 1.1 of the system manual for the product type.
- 3(1)(b): See the title page and preface of the system manual for the trademark and manufacturer's address.
- 3(1)(c): See the title page of the system manual for product model number(s).
- 3(1)(d): See the serial number on the physical system to determine the year of manufacture.
- 3(1)(e-j): **PSU Efficiency and Power Factor Value (Table) (From 80 Plus report)**

PSU Model #: PWS-1K23A-1R Watts: 860W	PSU Efficiency				Power Factor
	10 %	20 %	50 %	100 %	
<b>% of Rated Load</b>	<b>10 %</b>	<b>20 %</b>	<b>50 %</b>	<b>100 %</b>	<b>50 %</b>
Single Output (AC-DC)	91.79%	95.21%	96.37%	94.62%	0.98

### System (EUT) Efficiency in **Idle State** Power (Table)

Representative Configurations	Measured Idle State Power (W)	Calculated Idle Power Allowance (W)
High-End Performance Configuration	285.7	1118.21
Typical Configuration	N/A	N/A
Low-End Performance Configuration	331.5	626.01

### System (EUT) Efficiency in **Active State** Power (Table)

Representative Configurations	Active State Efficiency Score (Effserver)	Minimum Active State Efficiency for 2-Socket Server
High-End Performance Configuration	83.1	9.5
Typical Configuration	N/A	
Low-End Performance Configuration	48	

3(1)(k): The operating condition class is **A2**.

Operating condition class	Dry bulb temp °C		Humidity range, non-condensing		Max dew point (°C)	Maximum rate of change (°C/hr)
	Allowable range	Recommended range	Allowable range	Recommended range		
A1	15- 32	18-27	- 12 °C Dew Point (DP) and 8 % relative humidity (RH) to 17 °C DP and 80 % RH	- 9 °C DP to 15 °C DP and 60 % RH	17	5/20
A2	10-35	18-27	- 12 °C DP and 8 % RH to 21 °C DP and 80 % RH	Same as A1	21	5/20
A3	5-40	18-27	- 12 °C DP and 8 % RH to 24 °C DP and 85 % RH	Same as A1	24	5/20
A4	5-45	18-27	- 12 °C DP and 8 % RH to 24 °C DP and 90 % RH	Same as A1	24	5/20

3(1)(l): The idle state power at the higher boundary temperature of the operating conditions class is 285.7 W.

3(1)(m): The active state efficiency and performance is 83.1.

3(1)(n): There are two methods by which a user can securely delete data from this system. The user performing secure data deletion should be an IT professional.

The first is with a Unified Extensible Firmware Interface (UEFI) shell utility. This utility works on X10/X11/H11/H12/M11 motherboard series with onboard SATA/NVMe devices. Any user may access and download this utility through following link:  
[https://www.supermicro.com/about/policies/disclaimer.cfm?url=/wftp/utility/Lot9\\_Secure\\_Data\\_Deletion\\_Utility/](https://www.supermicro.com/about/policies/disclaimer.cfm?url=/wftp/utility/Lot9_Secure_Data_Deletion_Utility/)

Download the shell utility package and extract it to a USB flash drive, then plug the drive into the server for which secure data deletion is necessary. Then turn the system on. Navigate to the BIOS setup menu, then place the server system into the UEFI shell environment. Follow the instructions in the README file to invoke the utility and complete the deletion.

The second method is through the secure data deletion tool provided by the original manufacturer of the hard drive. This should be used in a scenario where the shell utility is not applicable. Each manufacturer should have the tool available on their website. If needed, please look on the hard drive label for the name of the manufacturer and model information.

3(1)(o): List of recommended combinations of blade servers with chassis: N/A.

3(1)(p): List of all current SKUs within this product family: AS -2015CS-TNR.

3(3)(a): There is no use of cobalt in batteries in this product.

The indicative weight range of neodymium in the HDD is 0.0 if manufactured by Western Digital, and is between 5-25 grams if manufactured by Seagate.

3(3)(b): Please see the disassembly instructions on the next page.

## Illustrated System Disassembly Instructions

*Please note: All the illustrations in the below disassembly instructions are for demonstration only. Components shown here may not match exactly with the components in your system.*

**CAUTION: Always power off the system and unplug the power cord(s) first before disassembling the system!**

---

### 1. Chassis Cover

*Type and number of fastenings:* Two (2) latches and two (2) Philips screws.

*Tools required:* Screwdriver with PH2 bit.

*Procedure:* Push down on the two buttons simultaneously while pushing the top cover off toward the rear of the system.

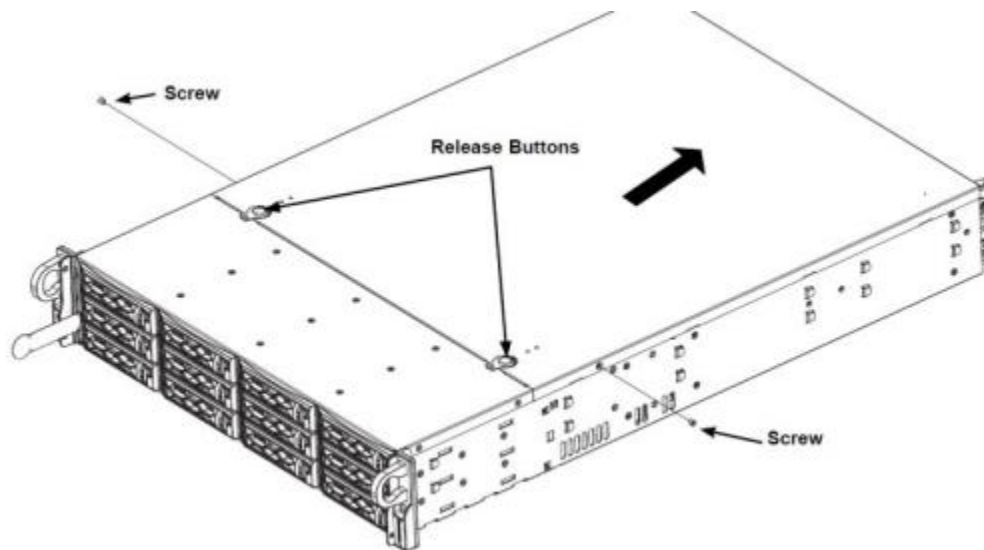

---

## 2. Data Storage Devices

Type and number of fastenings: One (1) latch for 3.5" drives, and one (1) latch and four (4) Phillips screws for 2.5" drives.

Tools required: For the model with 3.5" drives, none. For the model with 2.5" drives, a screwdriver with PH2 bit.

Procedure: Press the release button on the drive carrier to extend the drive carrier handle. Swing the handle open and pull the carrier out of its bay. For 3.5" drives, push the drive at the back of the tray opening to detach the drive. For 2.5" drives, unscrew the four Phillips screws to detach the drive.

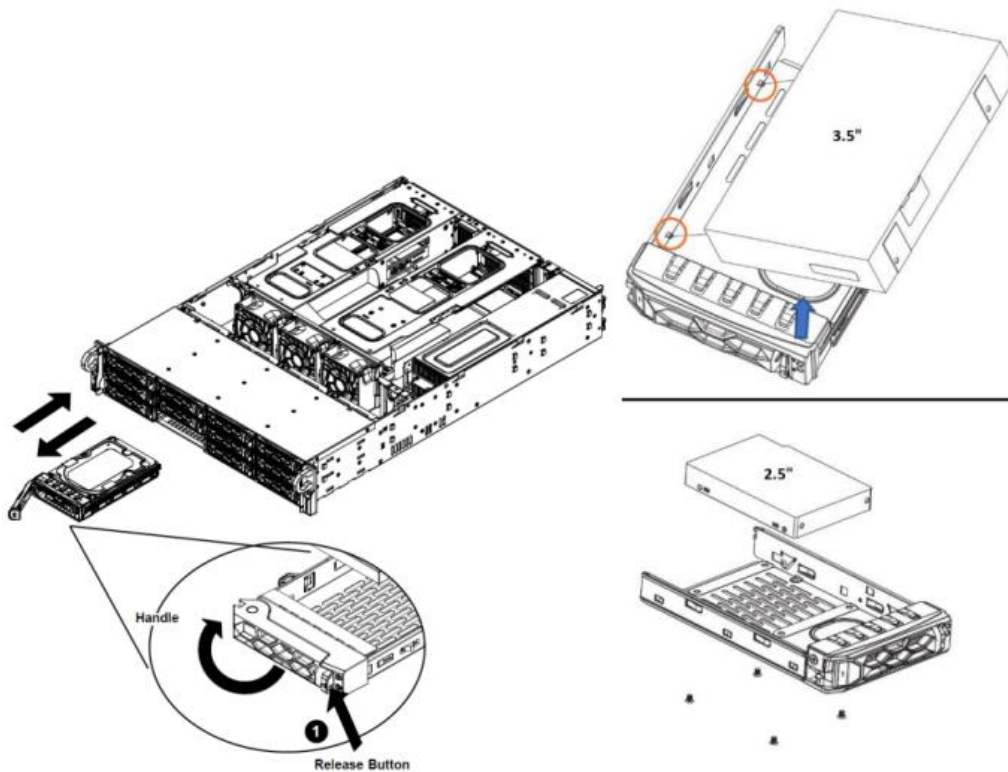

---

### 3. Memory

Type and number of fastenings: Two (2) latches per memory module.

Tools required: None.

Procedure: Press both release tabs on the ends of the memory module to unlock it. Once the module is loosened, remove it from the memory slot.

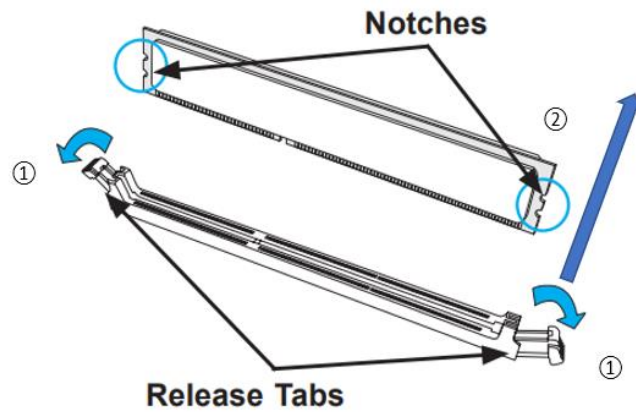

---

## 4. Processor

Type and number of fastenings: Seven (7) T20 Torx screws: six (6) on heatsink, one (1) on CPU socket frame.

Tools required: Screwdriver with T20 Torx bit.

Procedure: Remove the screws in the sequence of 6, 5, 4, 3, 2, 1, as shown in the picture below. After removing the screws, lift the heatsink module off the socket. Then loosen the socket screw. After loosening, remove the processor from the socket.

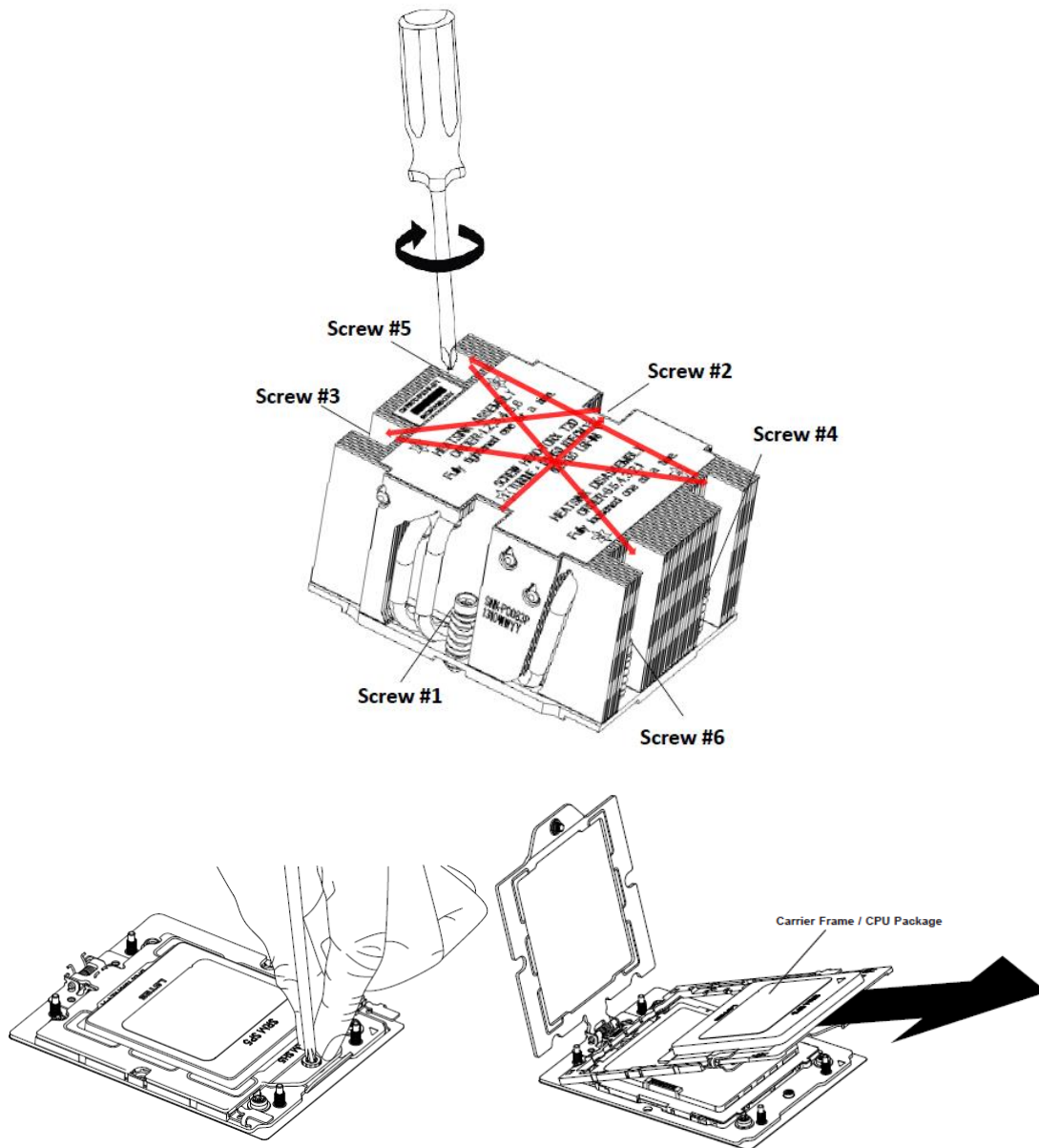

---

## 5. Fan

Type and number of fastenings: One (1) fan header per fan.

Tools required: None.

Procedure: Press the latch and pull up to disconnect the fan from the housing.

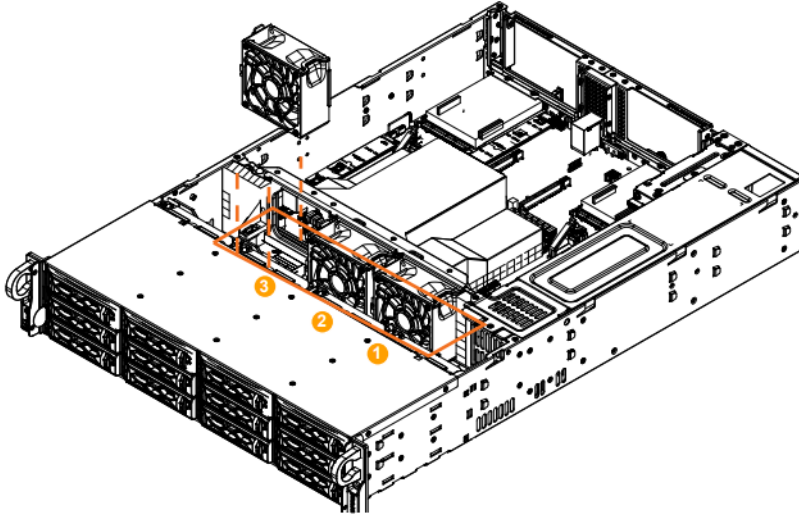

---

## 6. Power Supply Module

*Type and number of fastenings:* One (1) latch per module.

*Tools required:* None.

*Procedure:* Unplug the power cord from the power supply. Push the release tab on the back of the power supply module to the side and pull the module straight out.

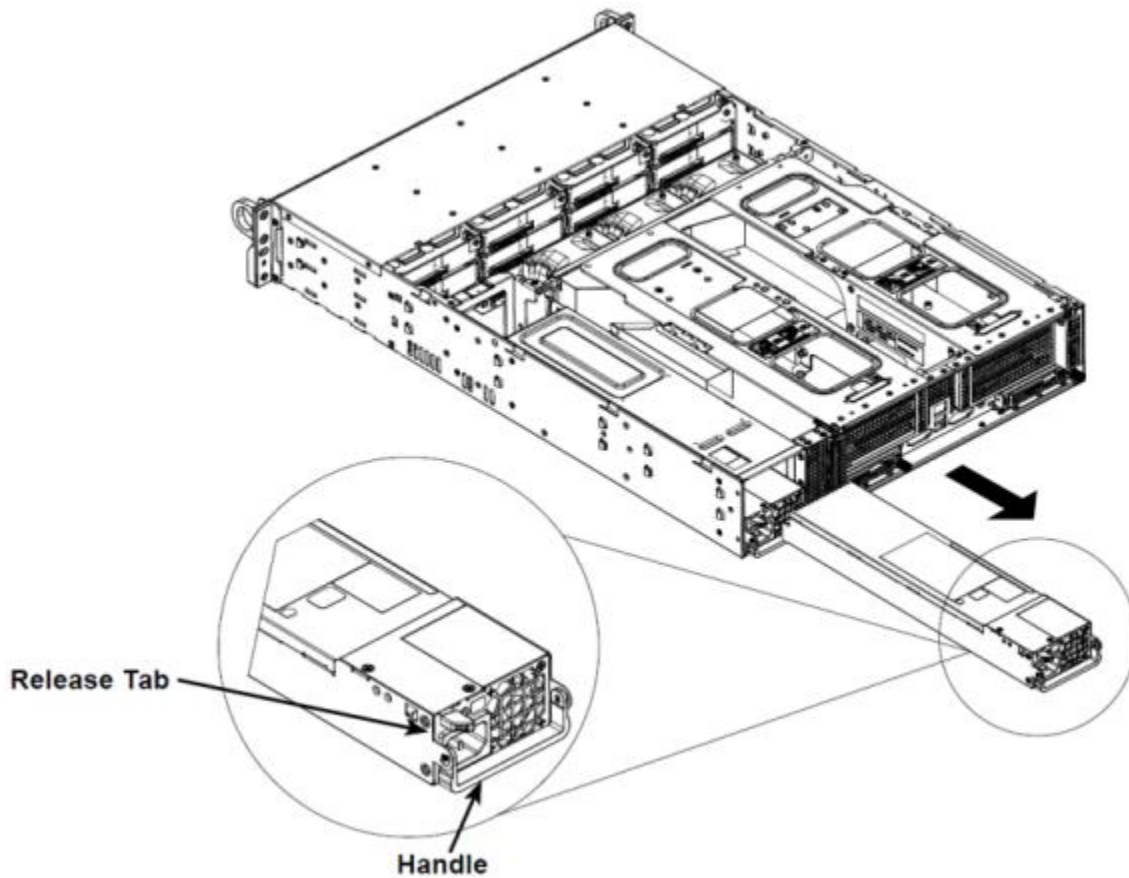

---

## 7. AIOM/OCP NIC 3.0 Card

Type and number of fastenings: One (1) thumbscrew on AIOM card or AIOM window.

Tools required: Screwdriver with PH2 bit.

Procedure: Unscrew the thumbscrew on the AIOM, then pull out the AIOM card from the slot.

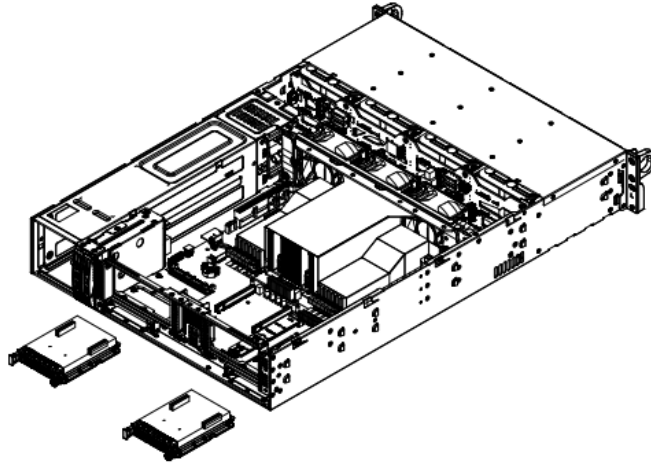

---

## 8. PCIe Expansion Card

Type and number of fastenings: None.

Tools required: : None

Procedure: Unplug any cables connected to the riser card. Open the rear window latch and carefully remove the expansion card from the riser card slot, lifting it up and away from the system.

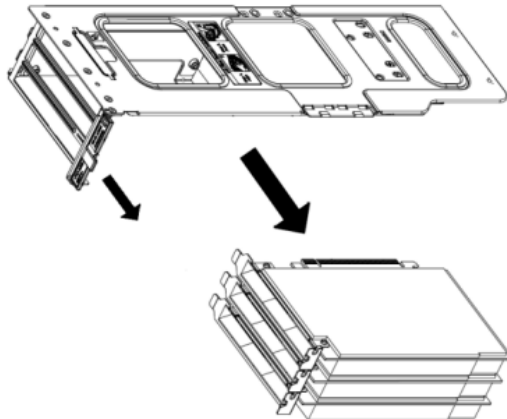

---

## 9. Riser Card

*Type and number of fastenings:* None.

*Tools required:* None.

*Procedure:* Unplug any cables connected to the riser card and lift the riser card bracket from the motherboard expansion slot.

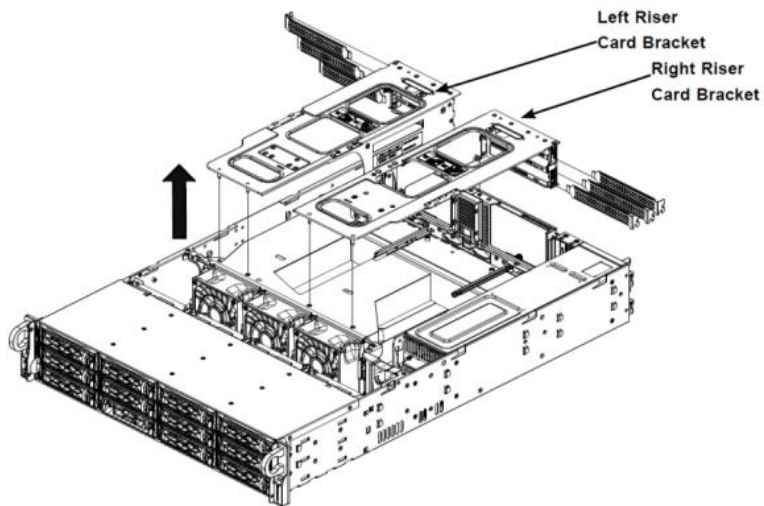

---

## 10. Motherboard

*Type and number of fastenings:* Seven (7) Phillips screws.

*Tools required:* Screwdriver with PH2 bit.

*Procedure:* Remove all seven Phillips screws. Lift the motherboard from its base.

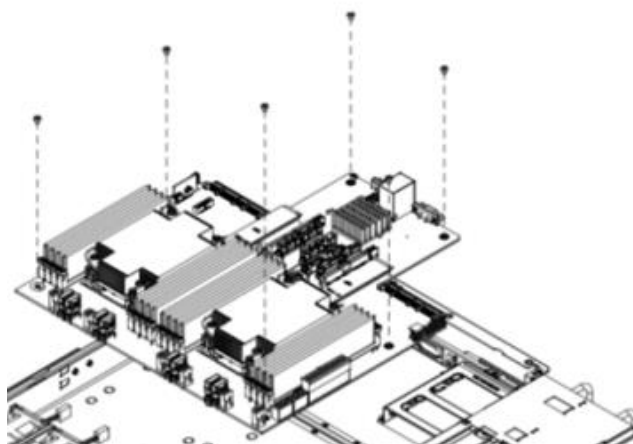

---

## 11. Backplane

Type and number of fastenings: Four (4) Phillips screws.

Tools required: Screwdriver with PH2 bit.

Procedure: Disconnect all cables. Pull out the backplane assembly from the chassis. Then remove the four screws that secure the backplane to the assembly. Detach the backplane from the assembly.

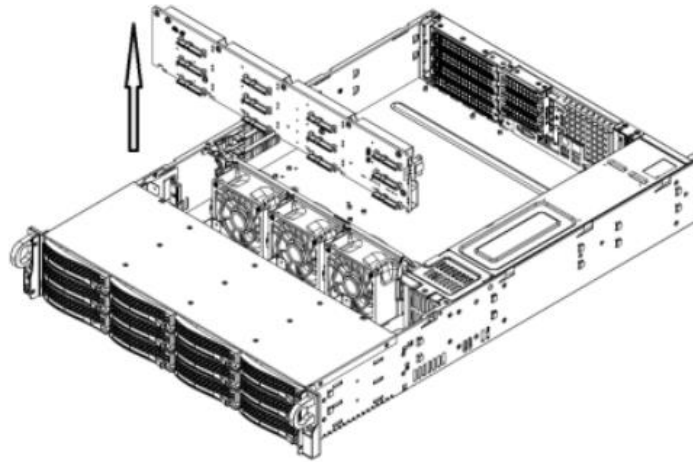

---

## 12. Power Distribution Board

Type and number of fastenings: Three (3) Phillips screws.

Tools required: Screwdriver with PH2 bit.

Procedure: Remove the four Phillips screws. Lift the power distribution board from its base.

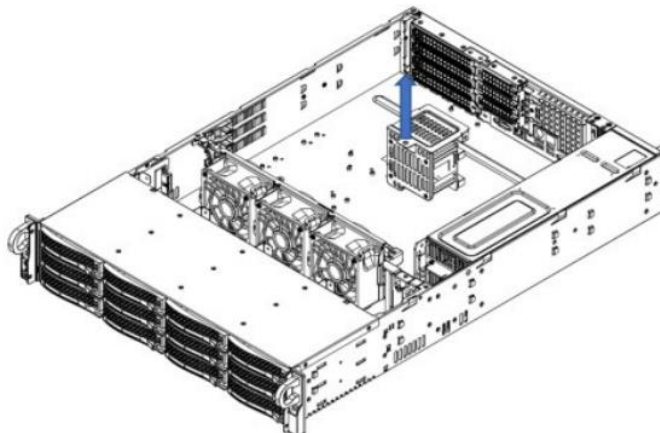

---

### 13. Batteries

Type and number of fastenings: One (1) latch.

Tools required: None.

Procedure: Push aside the small clamp that covers the edge of the battery. When the battery is released, lift it out of the holder.

